

Table of Content 755521B001

1. User manual	2
2. Legal regulations	3
3. Safety instructions	4
4. Technical data	5
5. Performance graph	6
6. Mounting	7
7. Cut Out Dimension	8
8. Controller	9
9. Wiring Diagram	10
10. Taking into Operation	11
11. Maintenance & Cleaning	12
12. Maintenance	12
13. Transport & Storage	13



1. User manual

This instruction manual contains information and instructions to enable the user to work safely, correctly and economically on the unit. Understanding and adhering to the manual can help one:

- Avoid any dangers.
- Reduce repair costs and stoppages.
- Extend and improve the reliability and working life of the unit.

PLEASE ENSURE TO USE THE RIGHT VERSION OF THE INSTRUCTION MANUAL SUITABLE FOR YOUR UNIT.

Intended use

The unit is to be used exclusively for the dissipation of heat from control cabinets and enclosures (stationary, not moving) in order to protect temperature sensitive components in an industrial environment. To meet the conditions of use, all the information and instructions in the instruction manual must be adhered to.



General danger

Indicates compulsory safety regulations which are not covered by a specific pictogram such as one of the following.



High electric voltage

Indicates electric shock danger.



Important safety instruction

Indicates instructions for safe maintenance and operation of the unit.



Attention

Indicates possible burns from hot components.



Attention

Indicates possible damage to the unit.



Instruction

Indicates possible danger to the environment.

2. Legal regulations

Liability

The information, data and instructions contained in this instruction manual are current at the time of going to press. We reserve the right to make technical changes to the unit in the course of its development. Therefore, no claims can be accepted for previously delivered units based on the information, diagrams or descriptions contained in this manual. No liability can be accepted for damage and production caused by:

- Disregarding the instruction manual
- Operating error
- Inappropriate work on or with the unit
- The use of non-specified spare parts and accessories
- Unauthorised modifications or changes to the unit by the user or his personnel

The supplier is only liable for errors and omissions as outlined in the guarantee conditions contained in the main contractual agreement. Claims for damages on any grounds are excluded.

3. Safety instructions

Upon delivery the unit is already meeting current technical standards and can therefore be safely taken into operation. Only authorised personnel is allowed to work on the unit. Unauthorised personnel must be prohibited from working on the unit. Operating personnel must inform their superiors immediately of any malfunction of the unit.

Please note that before starting to work on or with the unit, a procedure must be carried out inside the cabinet on which the unit is to be mounted.

Before commencing work inside the cabinet, the control cabinet manufacturer's instruction must be read with regards to:

- Safety instructions.
- Instructions on taking the cabinet out of operation.
- Instructions on the prevention of unauthorised cabinet reconnection.

The electric equipment meets the valid safety regulations. One can find dangerous voltages (above 50 V AC or above 100 V DC)

- Behind the control cabinet doors.
- On the power supply in the unit housing.

The unit has to be operated according to the type plate and the wiring diagram, and must be protected externally from overloading and electrical faults via suitable protective devices.



Danger through incorrect work on the unit

The unit can only be installed and maintained by technical competent and qualified personnel, using only supplied material according to the supplied instructions.



Danger from electrical voltage

Only specialised personnel are allowed to maintain and clean the unit. The personnel must ensure that for the duration of the maintenance and cleaning, the unit is disconnected from the electrical supply.



Attention

Damage to the unit through the use of inappropriate cleaning materials. Please do not use aggressive cleaning material.



Instruction

Damage to the environment through unauthorised disposal. All spare parts and associated material must be disposed according to the environmental laws.

4. Technical data

Order Number	755521B001
Cooling capacity L35W10 (200 l/h)	5.5 kW (800l/h)
Coolant	Water, light oils or similar
Operating Temperature Range	1°C - 60°C
Air flow volume (system / unimpeded)	780 / 1,100 m ³ /h
Mounting	Wall mounted / recessed
Housing Material	Mild steel, powder coated
Dimensions A x B x C (D+E)	1,550 x 455 x 232 (37+195) mm
Weight	39 kg
Voltage / Frequency	380-415 V 50 Hz 3~ 400-460 V 60 Hz 3~
Starting current	0.9 / 1.0 A
Max. current	0.4 / 0.5 A
Max. power	170 / 250 W
Pressure water circuit	10 bar
Water connection	Rp 1/2" - inside thread (with optional connectors for pipe internal diameter of 13 mm)
Noise level	5.5 kW L35W10 (800l/h)
Fuse	2 A (T)
Connection	5 - pole terminal for signals 4 - pole terminal for power
Ingress Protection	IP 55 / Type 12, 3, 3R, 4, 4X
Approvals	CE, cURus, cULus

5. Performance graph

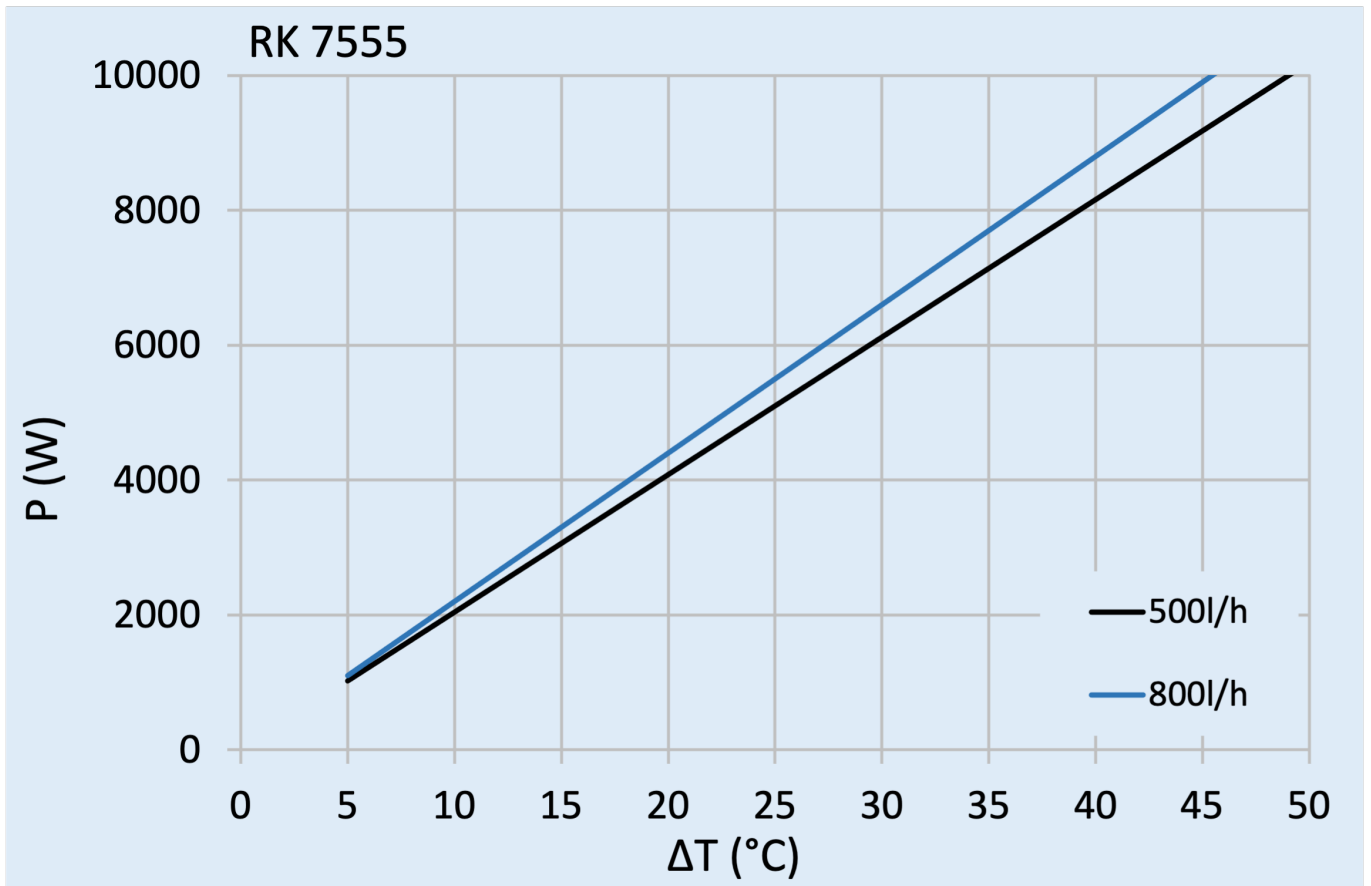

6. Mounting



The power supply rating on unit rating plate must comply with mains rating.



Always disconnect the power supply before opening the unit.

SLIMLINE HEX air/ water heat exchangers have an extremely compact design and construction, giving them the advantage of occupying very little space. In addition, the SLIMLINE HEX models can be wall mounted or semi recessed, as required.

To achieve a good seal between the control cabinet and the heat exchanger, the unit's mounting surface on the control cabinet may need to be reinforced. The air intake and outlet must not be obstructed by equipment inside the control cabinet, so that the air is mixed thoroughly and thermal stratification is avoided.

For the heat exchanger to work perfectly, the cabinet must be completely sealed from its surroundings. An imperfectly sealed control cabinet will result in an increased level of condensation. The control cabinet should have a minimum of IP54 protection, in accordance with IEC 60 529.

Cooling medium connection

There are two pipe connection points in the bottom or in the top of the unit to connect the coolant supply. The pipe connectors have a G3/8" or G1/2" female thread depending on version. Before connecting the coolant circuit, note the flow direction of the coolant medium. Next to the pipe connectors, there are labels to identify the inlet and outlet of the coolant medium. A small indent is also present in the housing next to the inlet port. To empty the unit connect the water inlet pipe to a compressed air supply and route the water outlet pipe to a location where the water can be drained. If a solenoid valve is installed on the unit this will be open if the unit is turned off. Slowly open the compressed air supply till all the water in the heat exchanger is flushed out. Ensure that the pressure of the system is below the rated pressure of the unit and fitting.

7. Cut Out Dimension

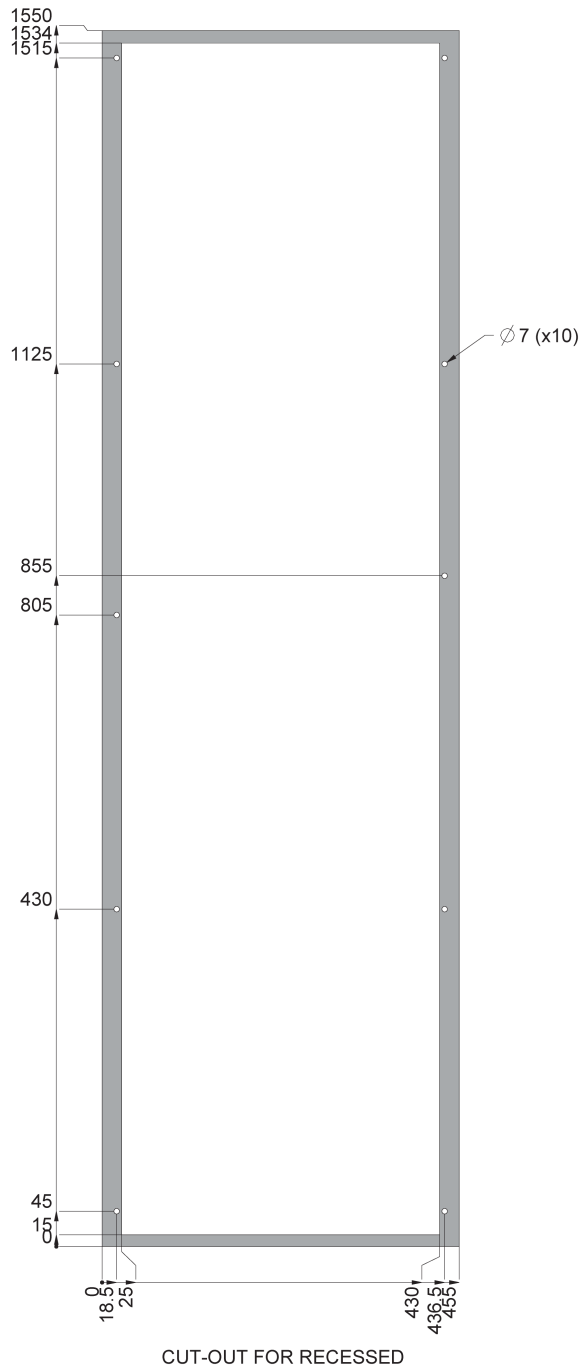
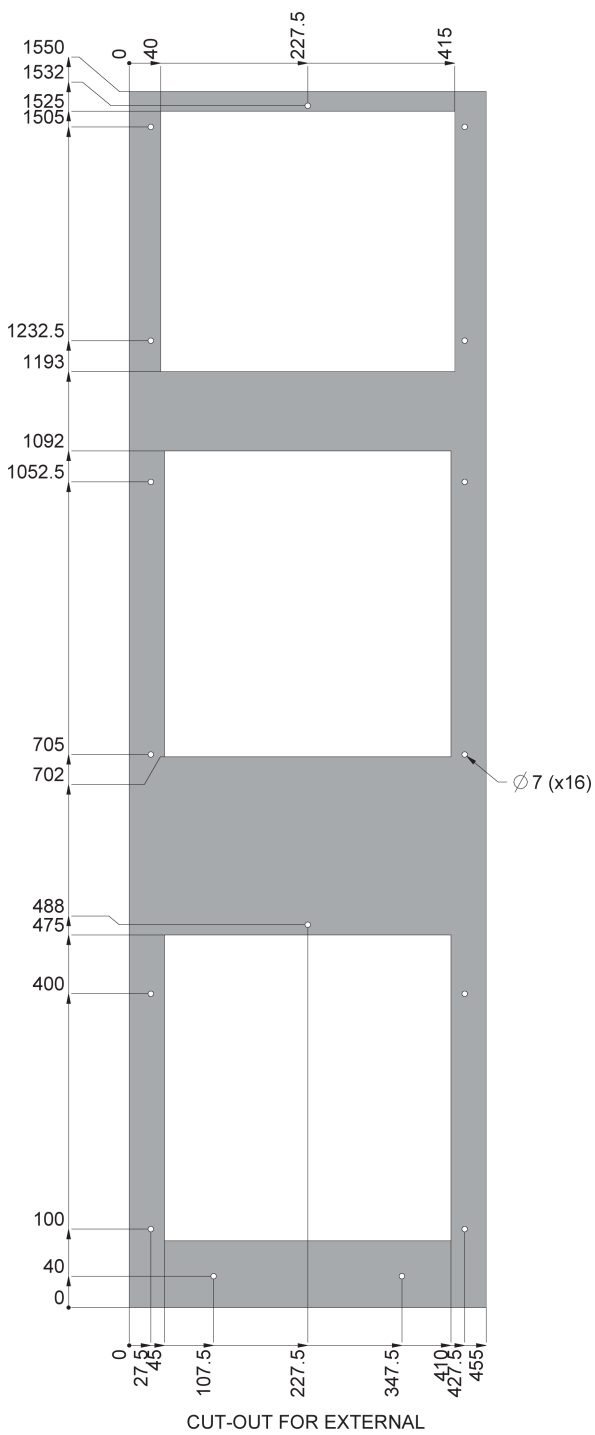

8. Controller

Adjusting the control setpoint

The cooling set point can be adjusted between 0°C and 60°C. The setpoint is controlled by parameter **St**. The default setting is 25°C.

To change the control setpoint:

Press the red **Set** button for 1 second until **St** appears on the display.

Press the **Up/Down** buttons to reach the desired value.

Press the **Set** button to save the new setting.

Adjusting the high and low temperature alarm setpoints

The high temperature alarm setpoint is controlled by parameter **AH**. The default setting is 55°C.

The low temperature alarm setpoint is controlled by parameter **AL**. The default setting is 0°C.

Adjusting parameters

- Press and hold **SET** for 3-5 seconds until **PS** is displayed.
- Release and press **SET** again briefly to display **0**.
- Press the **UP** arrow until you reach the value of **22**. Then press **SET**. (This is the factory password to access the protected parameters). Once the parameter list is accessed, **PS** is again displayed.
- Press the **UP** or **DOWN** buttons to scroll through the various parameters.
- Press **SET** to display the selected parameter's stored value if needed.
- Press **UP/DOWN** to change the parameter value if needed.
- Press **SET** to save the current value displayed.
- When ready from parameter adjustment, press and hold **SET** for 5 seconds to save any changes made.
- The display will return to temperature reading. (This last step has to be performed correctly or all the parameter changes are lost.)

Behaviour of digital input

The unit can be switched on and off via a door contact switch (optional). When delivered the door contact terminals are bridged on the female connector. To connect the door contact switch remove the bridge and connect door contact switch. The contact must be closed when the cabinet door is closed.

Attention

The unit can be damaged through incorrect adjustment. Do not modify any other values other than those specified above. Adjusting other values may result in incorrect operation and damage to the unit.

9. Wiring Diagram

- Power connector
 PE
 L3
 L2
 L1
- Signal connector
 Door contact T2
 Door contact T1
 /
 Alarm contact P2
 Alarm contact P1
- TOP connector
 TOP
 TOP
 /

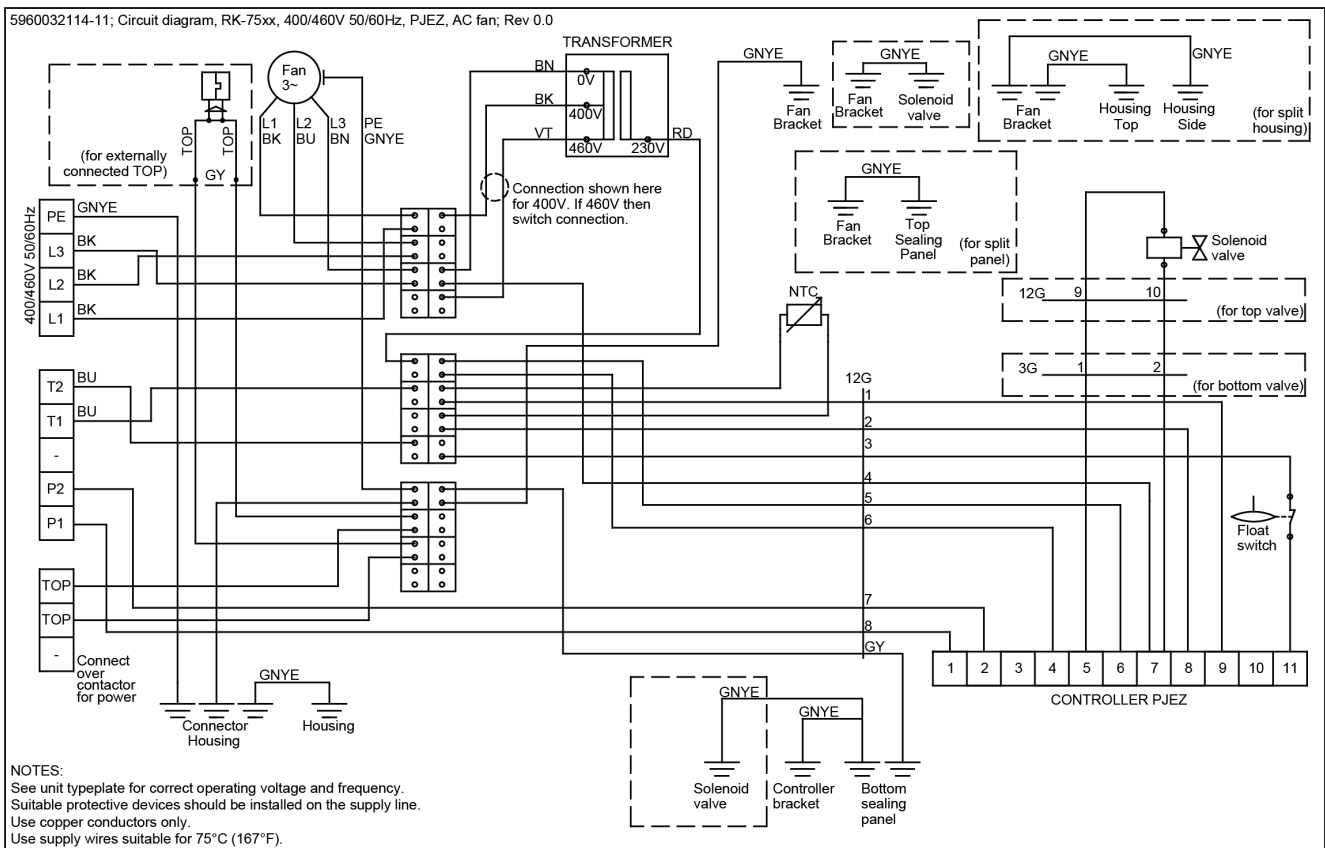

10. Taking into Operation

The cooling performance of the heat exchanger is dependent on the water flow rate available from the supply. The water flow is dependent on the water supply system to which the heat exchanger is connected and is affected by various factors, such as conduit pressure, conduit diameter, etc.

1. Units without water flow regulator

These units do not have any automatic control functions.

2. Units with Solenoid valve

The solenoid valve is switched electrically. If the unit power is off, the valve is open.

3. Units with temperature controller

The unit is equipped with a temperature controller which regulates the function of the unit. On normal working conditions the display shows the temperature inside the enclosure. The controller "set point" for the interior of the enclosure (parameter St) is pre-set at 25°C and can be adjusted between +20°C and +50°C.

The High temperature alarm (parameter AH) is preset at 55°C.

Modifying controller parameters

1. Press the SET button for more than 3 sec. (if there are active alarms, mute the buzzer). The display shows the parameter code 'PS' (password).
2. Only for parameters requiring password: Press the SET button to access the password setting, use the UP and DOWN buttons to scroll the numbers until displaying, "22" (default password to access the parameters), press the SET button to confirm the password
3. Use the UP and DOWN buttons to scroll the parameters. The LED corresponding to the category of parameters will be on
4. Press SET to display the value associated with the parameter
5. Increase or decrease the value using the UP or DOWN button respectively
6. Press SET to temporarily save the new value
7. Press the SET button for more than 3 sec. to permanently save the new parameters and exit the parameter setting procedure.

If no button is pressed for 60 sec. all changes made to the parameters, temporarily saved in the RAM, will be cancelled and the previous settings restored. The cooling unit manufacturer is in no way liable for any alterations the customer may make to the factory set parameters, unless the manufacturer has authorized the customer in writing to change them.

This manual is intended as quick reference for controller, for a full controller manual or if you need to restore the factory parameters please go to our website to download the full manual or to locate your nearest servicing office.

4. Units with door switch

The unit can be switched on and off via a door contact switch (optional). When delivered the door contact terminals are bridged on the female connector. To connect the door contact switch remove the bridge and connect door contact switch. The contact must be closed when the cabinet door is closed.

11. Maintenance & Cleaning

The unit should have regular functional tests (approx. every 2,000 hours depending on the grade of ambient pollution).

12. Maintenance

Every unit is given a performance test under load at the factory. The units are largely maintenance-free, however, the following points should be observed:

1. Fan replacement

Before replacing the fan, the equipment must be switched off from the power supply (pull out mains plug or connecting cable). The rated life time of the fan is L10 = 30.000 hours under normal operational conditions. Should it become necessary to replace the fan, remove the support for the fan by loosening the 4 fastening screws. To detach the fan from the fan support loosen a further 4 screws and the fan connecting cable. When connecting the new fan, take care that the correct polarity is maintained.

2. Controller replacement

Before replacing the controller, isolate the equipment from the power supply (pull out mains plug or connecting cable). Detach the controller from its support by unclipping the unit and the connectors. When connecting the new controller make sure that the correct polarity is maintained.

3. Environmental protection

If the heat exchanger has reached its end of life state, we will dispose it if it is returned to us freight paid.

4. Maintenance work on the unit

All the maintenance operations described above should only be carried out by expert personnel. All work on the cooling circuit should only be carried out at the factory.

13. Transport & Storage

- Malfunction due to transport damage. During transport and storage the heat exchanger must be kept in the position marked on the box and at a temperature between -40°C and 70°C and a relative humidity of max. 95% (at 25°C). Check the packaging has not been damaged during shipping.*
- Damage to the unit through incorrect transport. Please ensure that all liquid has been removed prior any transport.*

To avoid transport damage the unit should be returned in the original packing or in a packing case and must be strapped to a pallet. If the unit cannot be returned in the original packing please ensure that:

- A space of at least 30 mm must be maintained at all points between the unit and the external packing.
- The unit must be firmly fixed in the packing.
- The unit must be protected by shock-resistant padding (hard foam corners or cardboard corners).

Seifert Systems GmbH Albert-Einstein-Str. 3 42477 Radevormwald Germany Tel.+49 2195 68994-0 info.de@seifertsystems.com	Seifert Systems Ltd. HF09/10 Hal-Far Industrial Estate Birzebbuga, BBG 3000 Malta Tel.+356 2220 7000 info@seifertsystems.com	Seifert Systems AG Wilerstrasse 16 4563 Gerlafingen Switzerland Tel.+41 32 675 35 51 info.ch@seifertsystems.com	Seifert Systems GmbH Bärnthäl 1 4901 Ottnang Austria Tel.+43 7676 20712 0 info.at@seifertsystem.com	Seifert Systems Ltd. Rep. Office 26100 Cremona Italy Tel.+39 349 259 4524 info@seifertsystems.com	Seifert Systems Inc. 75 Circuit Drive North Kingstown RI 02852 USA Tel.+1 401-294-6960 info.us@seifertsystems.com	Seifert Systems Pty Ltd. 105 Lewis Road Wantirna South 3152 Victoria Australia Tel.+61 3 98 01 19 06 info@seifertsystems.com.au
--	---	---	---	---	--	--